

THE ZELIOX ENERGY STORAGE SYSTEM



EFFICENCY, FLEXIBILITY, RELIABILITY

The Zeliox features a built-in battery heater for reliable cold-weather performance, a smart app for real-time monitoring, and advanced safety features like deep discharge protection and insulation guard, ensuring efficient and secure power management.



ZELIOX CONTROL MODULE

The Zeliox Control Module (ZCM) is a stand-alone smart power distribution system that easily connects to your vehicle battery, splitting power into 6 programmable channels for seamless accessory management with RF-controlled buttons and app integration.

PRODUCT	ZELIOX ECO SLIM	ZELIOX ECO I	ZELIOX ECO II	ZELIOX ECO III
Power	1000 W	1600 W	2000 W	3000 W
Surge peak	1250 W	3200 W	4000 W	6000 W
Capacity	0.64 kWh	1.3 kWh*	1.3 kWh*	2.6 kWh*
Battery capacity	50 Ah	100 Ah	100 Ah	200 Ah
Battery type	Lithium 12.8V	Lithium 12.8V	Lithium 12.8V	Lithium 12.8V
Built-In DC-DC converter	30 A	30 A	30 A	60 A
Charging while driving	1:45 h	1:45 h	1:45 h	3:30 h
Charging via solar 300 W	2:10 h	4:20 h	4:20 h	8:40 h
Charging via shore power	-	1:45 h (60 A)	1:45 h (60 A)	1:45 h (120 A)
Weight	19.2 kg	33 kg	35 kg	54 kg
Dimensions w x d x h	445 x 392 x 195 mm	450 x 392 x 225 mm	450 x 392 x 225 mm	520 x 392 x 303 mm

*Expandable



Contact us!
eberspaecher-zeliox.com

EBERSPÄCHER CLIMATE CONTROL SYSTEMS INTERNATIONAL GMBH
EBERSPÄCHERSTRASSE 24
73730 ESSLINGEN / GERMANY

PHONE: +49 711 939-00

FAX: +49 711 939-0634

info@eberspaecher.com

www.eberspaecher-zeliox.com

A WORLD OF COMFORT



ENERGY STORAGE SYSTEM / ZELIOX

ZELIOX – MOBILE POWER. ANYWHERE. ANYTIME.

The mobile All-in-One power solution.

WHAT IS ZELIOX?



The Zeliox is a versatile All-in-One power solution designed for mobile energy needs. With multiple versions and expansion options, it delivers clean, uninterrupted power for tools, appliances, and accessories. The plug & play installation makes setup effortless, while various charging methods keep you powered wherever you go. Whether in service vans, construction trailers or remote locations, the Zeliox ensures efficient, flexible, and secure energy.

KEY FEATURES:

Reliable energy – The All-in-One power solution with battery, inverter, and safety features ensures stable 230V & 12V energy, eliminating complex installations.

Plug & Play installation – Quick setup with secure connectors and no complex wiring required.

Versatile charging compatibility – Designed to integrate with various power sources, including vehicle alternators, mains, and solar (depending on model).

Seamless power integration – Built-in 230V socket and DC-DC converter ensure efficient and direct energy supply for tools, appliances, and vehicle accessories.



YOUR ZELIOX – THE WAY YOU NEED IT

Enhance your Zeliox system with accessories for greater flexibility and efficiency. Add sockets, solar panels, expand capacity with additional battery packs, add an external charging point for easy shore power connection and more. With modular add-ons, the Zeliox adapts to any professional need.



Want to know more?
Find all details on
[eberspaecher-zeliox.com](https://www.eberspaecher-zeliox.com)

SLIM - CASUAL USE

1000 W / 0.64 KWH

Chargers, small tools, ...

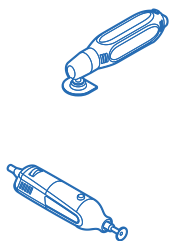

ECO I - LIGHT USE

1600 W / 1.3 KWH

Soldering irons, heatguns, ...

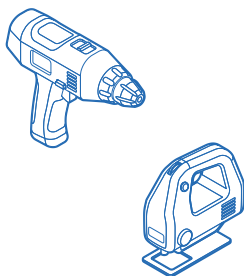

ECO II - MEDIUM USE

2000 W / 1.3 KWH

Circular saws, fridges, ...

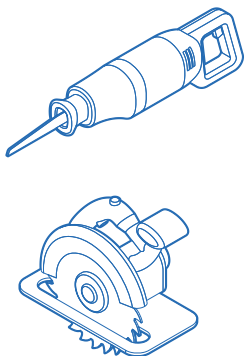

ECO III - HEAVY USE

3000 W / 2.6 KWH

Compressors, chainsaws, ...

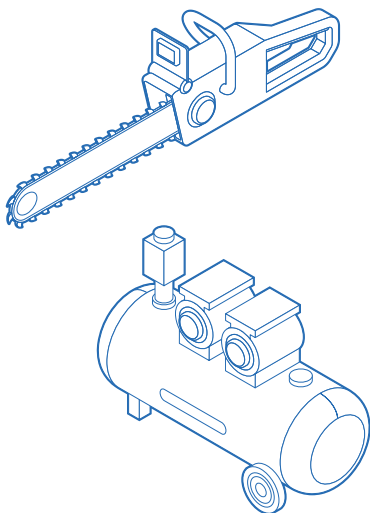

ENERGY FOR EVERY APPLICATION

Available in various models, the Zeliox ensures the right power solution for every need. Whether for light applications, professional tools, or heavy-duty equipment, each system delivers reliable, scalable, and efficient energy wherever it's needed.